

*University of Portland*  
*School of Engineering*

**EE 261-Electrical Circuits-3 cr. hrs.**  
**Spring 2007**

**Midterm Exam # 3**

(Friday, April 20, 2007)

(Closed Book Exam, Three Formula Sheet are Allowed)

(Total Time: 55 minutes)

**Name:** \_\_\_\_\_ 😊

**Signature:** \_\_\_\_\_ 😊

*“An honest mind possesses a kingdom.”*  
Lucius Annaeus Seneca (4B.C.–65A.D.)

*“Honest people are the true winners of the universe.”*  
Anonymous

**NOTE:** On all the problems, please show your work clearly, and provide the appropriate units for your answers. Also mark on the schematic to show any current or voltage that you define in your solution.

1. (15 mins., 30 points) In the circuit shown, find the complete mathematical expression for the current  $i_L(t)$  through the 0.12 H inductor for  $t \geq 0$ . (Please show your work clearly and provide brief justifications for the steps you take. Also, don't forget to provide the correct units for your answers.)

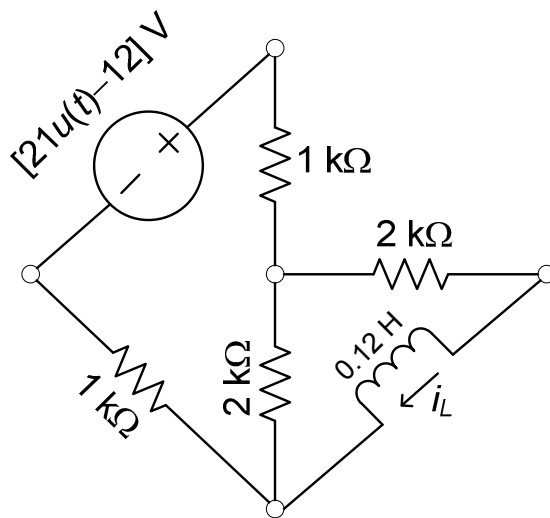

2. (15 mins., 30 Points) In the circuit shown below, the switch opens at  $t=0$ , after being closed for a long time. Find the complete mathematical expression for the voltage  $v_C(t)$  and the current  $i_C(t)$  of the  $1/3 \mu\text{F}$  capacitor for  $t \geq 0$ . (Please show your work step by step. Also, again, provide appropriate units.)

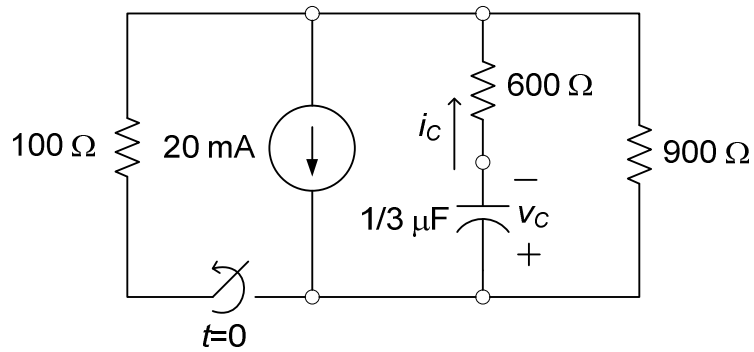

3. (20 mins., Total: 40 Points) Consider the second-order circuit shown.

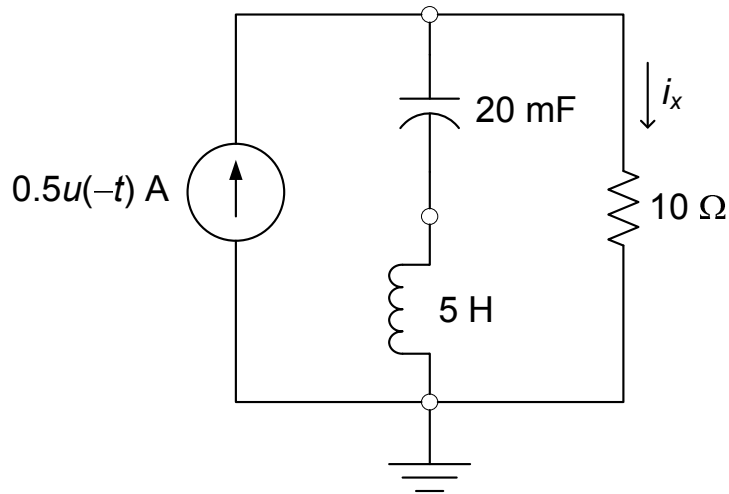

(a) (15 points) Solve for the roots ( $s_1$  and  $s_2$ ) of the characteristic equation of the above circuit for  $t \geq 0$ .

(b) (10 points) Based on the results of part (a), write the general mathematical expression for the current  $i_x(t)$  for  $t \geq 0$ . (At this stage, leave the coefficients in your answer as unknown variables.)

(c) (15 points) Find the values of the coefficients of the  $i_x(t)$  expression found in part (b) using the initial and final conditions.