

# Sample Write-Up Format for EE 271 Lab Experiments

The following is a sample write-up format for the EE 271 lab experiments. Please follow this format for all your write-ups in your lab notebooks this semester. Note that the write-up is provided in italics form.

## SAMPLE LAB REPORT WRITE-UP

PROVIDE THE DATE! → *January 17, 2016*

PROVIDE YOUR INITIALS! → *BF*

PROVIDE THE TITLE! → *Experiment # 1: Ohm's Law and Kirchhoff's Laws*

### *I. Objective* ← PROVIDE SUBTITLES!

*In this experiment, the student will learn how to read resistor color codes and how to measure voltage, current, and resistance with the digital multimeter (DMM). The student will also build circuits and take measurements to verify Ohm's law, Kirchhoff's laws, and the conservation of energy.*

*1(a)-Prelab Assignment:* ← PROVIDE SUBTITLES! *The color code for a 10 kΩ resistor with 5% tolerance will be Brown-Black-Orange-Gold.*

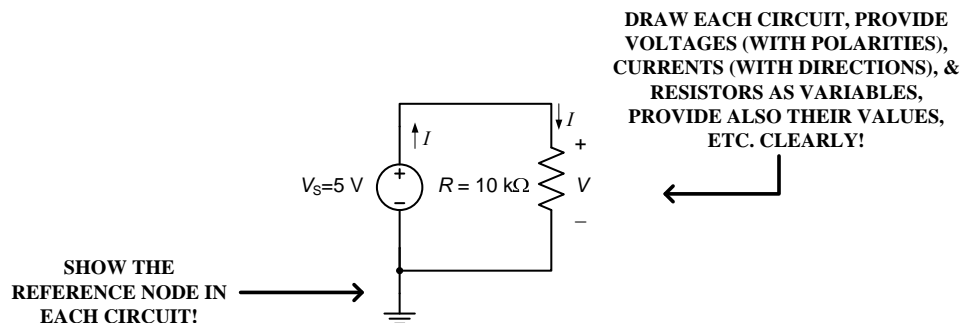

Figure 1. Circuit for pre-lab 1(a).

Note that in Figure 1, the resistor voltage  $V=5\text{ V}$  based on KVL. In addition, note that the currents of the voltage source and the resistor are equal based on KCL. Using Ohm's law, we can find the current  $I$  as (next page)

$$I = \frac{V}{R} = \frac{5\text{ V}}{10\text{ k}\Omega} = 0.5\text{ mA} \leftarrow \text{PROVIDE APPROPRIATE UNITS!}$$

Next, the power absorbed by the resistor can be calculated as  $p_R = I^2 R = (0.5 \text{ mA})^2 (10 \text{ k}\Omega) = 2.5 \text{ mW}$ . Yes, it is safe to use resistors with 0.25 W power ratings in this experiment since  $2.5 \text{ mW} < 0.25 \text{ W}$ . The power supplied by the voltage source can be obtained as  $p_S = V_S I = (5 \text{ V})(-0.5 \text{ mA}) = -2.5 \text{ mW}$ . Note that the minus sign of the value of the source power indicates that this is supplied power. Since  $p_S + p_R = -2.5 + 2.5 = 0$ , the conservation of energy principle is satisfied.

**1(a)-Lab Experiment: ←PROVIDE SUBTITLES!**

We will construct the circuit shown in Figure 2. First, we start by measuring the actual value of the 10 kΩ resistor. Always measure the resistor value without it being connected to anything else! Never measure the resistor value while it is connected to the bread board!!

Measured value of the 10 kΩ resistor using the handheld DMM is  $R_{\text{measured}} \cong 9.96 \text{ k}\Omega$ . The percentage error in the resistor value can be calculated as

$$\% \text{ error in the resistor value} = \frac{|R_{\text{theoretical}} - R_{\text{measured}}|}{R_{\text{theoretical}}} \times 100 = \frac{10 \text{ k}\Omega - 9.96 \text{ k}\Omega}{10 \text{ k}\Omega} \times 100 \cong 0.40\%$$

Since  $0.4\% < 5\%$ , the percentage error is less than the specified tolerance of the resistor.

Construct the circuit shown in Figure 2 using the 5-volt DC supply in your lab kit (the red terminal).

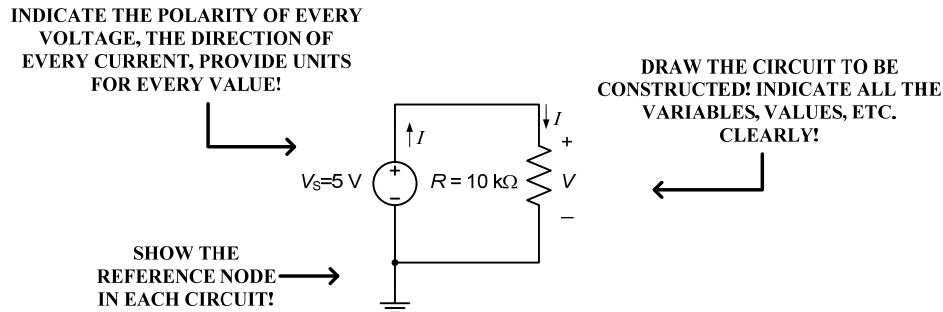

Figure 2. Circuit for lab experiment 1(a).

FIGURE NUMBER & CAPTION!

Measured  $V$  and  $I$  values using the handheld DMM in DC mode are  $V \approx 5.00 \text{ V}$  and  $I \approx 0.497 \text{ mA}$ . The percentage error between the theoretical and measured values of the current  $I$  can be calculated as

$$\% \text{ error in the current value} = \frac{|I_{\text{theoretical}} - I_{\text{measured}}|}{I_{\text{theoretical}}} \times 100 = \frac{0.5 \text{ mA} - 0.497 \text{ mA}}{0.5 \text{ mA}} \times 100 \cong 0.60\%$$

The difference between the theoretical and measured values of current could be due to the additional resistance introduced by the connecting wires which was ignored in the theoretical calculations.

Using the measured values of  $V$  and  $R$ , the predicted value of  $I$  using Ohm's law can be calculated as

$$I_{\text{predicted}} = \frac{V_{\text{measured}}}{R_{\text{measured}}} = \frac{5V}{9.96 \text{ k}\Omega} \cong 0.502 \text{ mA} \leftarrow \text{PROVIDE APPROPRIATE UNITS!}$$

Table 1. Theoretical and measured resistor, voltage and current values.  
(For circuit shown in Figure 2.)

$R_{th}$ (k $\Omega$ )	$R_m$ (k $\Omega$ )	$V_{th}$ (V)	$V_m$ (V)	$I_{th}$ (mA)	$I_{pr}$ (mA)	$I_m$ (mA)
10	9.96	5.00	5.00	0.5	0.502	0.497

Next, we calculate the percentage error between the predicted and measured values of the current  $I$  as follows:

$$\% \text{ error in the current value} = \frac{|I_{\text{predicted}} - I_{\text{measured}}|}{I_{\text{predicted}}} \times 100 = \frac{0.502 \text{ mA} - 0.497 \text{ mA}}{0.502 \text{ mA}} \times 100 \cong 1.00\%$$

The predicted and measured values for the current differ simply because the calculation of the predicted current doesn't take into account the resistances introduced by the connecting wires.

Using the measured values, the powers absorbed by the resistor and supplied by the voltage source can be calculated as  $p_R = I^2 R = (0.497 \text{ mA})^2 (9.96 \text{ k}\Omega) = 2.46 \text{ mW}$  and  $p_S = V_S I = (5V)(-0.497 \text{ mA}) = -2.49 \text{ mW}$  respectively. Yes, conservation of energy is approximately satisfied since  $p_S + p_R \cong 0$ . The difference between the two power values (which is  $\sim 0.03 \text{ mW}$ ) can be accounted as the power consumed by the wires and other parasitic resistances.

#### IV. Conclusion

The objective of this experiment was to construct simple resistive electric circuits to verify Ohm's law and Kirchhoff's laws. These laws were clearly used throughout this experiment. In general, our measured values agreed with our theoretical values. The differences were due to the accuracy of the instruments (the handheld DMM) used, parasitic resistances introduced by the conductor wires, etc. The maximum % error calculated was  $\sim 1.00\%$ . The errors between the measured and calculated values based on theory were mainly due to the inaccuracies introduced into the measured values by the handheld DMM, parasitic resistances introduced by the conductor wires, the conductors of the board, and other imperfections associated with the elements used to construct the circuits. In general, this experiment went very well and the goals of the experiment were achieved.