

University of Portland
School of Engineering

EE 271–Electrical Circuits Laboratory
Spring 2016

Lab Experiment #6:
First-Order RC Circuits as Low-Pass and
High-Pass Filters

First-Order RC Circuits as Low-Pass & High-Pass Filters

I. Objective

In this experiment, the students will make measurements and observations on the step and sinusoidal steady-state responses of simple first-order RC circuits. They will also understand how first-order RC circuits can be used as low-pass or high-pass filters.

II. Procedure

PART A: Step Excitation of First-Order RC Circuits

Pre-lab Assignment A.1: A first-order capacitive circuit is excited by a periodic rectangular pulse train as shown in Fig. 1. The element values of the circuit are given by $R_1=10\text{ k}\Omega$ and $C_1=10\text{ nF}$ respectively. Calculate the following:

- The time constant τ of this circuit (call this time constant $\tau_{\text{pre-lab}}$ or τ_p).
- Approximate time it takes for the capacitor to fully charge or discharge. (The time for the capacitor to fully charge or discharge corresponds to the time it takes for the capacitor voltage to reach approximately 99% of its final value.)

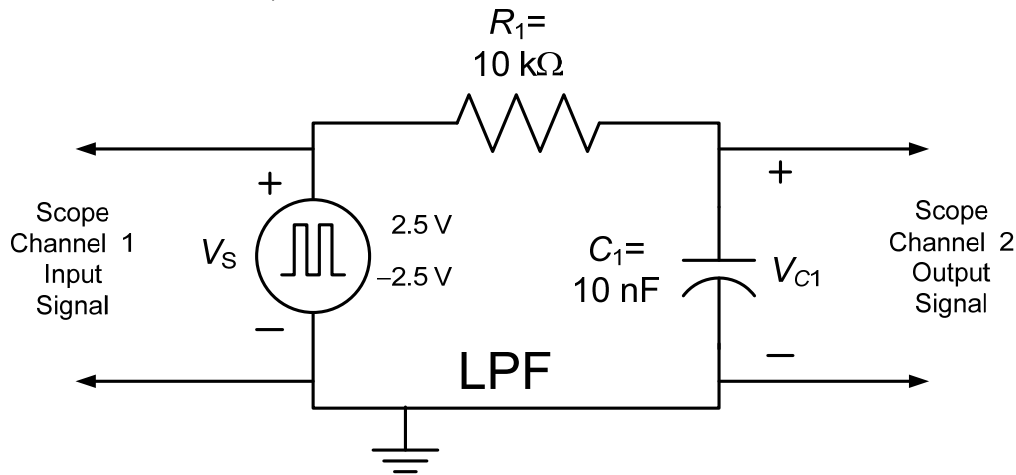

Figure 1. First-order RC circuit connected like a Low-Pass Filter (LPF).

Lab Experiment A.1: Construct the first-order RC circuit shown in Fig. 1 using $R_1=10\text{ k}\Omega$ and $C_1=10\text{ nF}$. Using the digital LCR meter, measure and record the actual values of the resistor and the capacitor used in your circuit. Use these actual element values measured to recalculate the time constant τ (call this time constant τ_{actual} or τ_a). Use the function generator available on your bench to supply the periodic rectangular pulse train to the circuit. Set the function generator to provide the rectangular pulse train represented with source voltage $V_S(t)$ which

oscillates between -2.5 V and 2.5 V (i.e., 5 V peak-to-peak) with frequency of oscillation $f = 1/T = 500\text{ Hertz (Hz)}$. (Note that $T=f^{-1}$ is the period of the periodic pulse train). Use the oscilloscope to monitor the source voltage $V_S(t)$ and the capacitor voltage $V_{C1}(t)$ simultaneously. Do the following:

- Measure the approximate value of the time constant τ of the circuit from the $V_{C1}(t)$ waveform (call this time constant τ_{measured} or τ_m). Note that over each $T/2$ time interval during which the source voltage $V_S(t)$ is either -2.5 V or 2.5 V , assuming $t=0$ to be the starting time of each one of these $T/2$ intervals, the capacitor voltage $V_{C1}(t)$ varies with respect to time as $V_{C1}(t) = V_{C1}(0)e^{-t/\tau_m} + V_{C1}(\infty)(1 - e^{-t/\tau_m})$ where $V_{C1}(0)$ is its initial value and $V_{C1}(\infty)$ is its final value. So, for example, the capacitor voltage at $t = \tau_m$ is approximately given by $V_{C1}(t = \tau_m) \cong 0.368V_{C1}(0) + 0.632V_{C1}(\infty)$. Refer to the middle portion of the $V_{C1}(t)$ sketch shown in Fig. 2 for which $V_{C1}(0) = -2.5\text{ V}$ and $V_{C1}(\infty) = 2.5\text{ V}$. Substituting these values yield $V_{C1}(\tau_m) \approx 660\text{ mV}$. Using this portion of the $V_{C1}(t)$ waveform seen on the oscilloscope display, measure and record the approximate value of the time constant τ_m using the $V_{C1}(\tau_m)$ voltage point on the $V_{C1}(t)$ waveform.

- Calculate the percentage error in the τ_m value measured using

$$\% \text{ error in } \tau_m \text{ value} = \left| \frac{\tau_a - \tau_m}{\tau_a} \right| \times 100$$

- Compare $T/2$ (or $1/(2f)$) with $\sim 5\tau_m$ and comment on the two waveforms ($V_S(t)$ and $V_{C1}(t)$) observed simultaneously on the scope. (Hint: Does the capacitor have enough time to fully charge over the time interval $T/2$?)

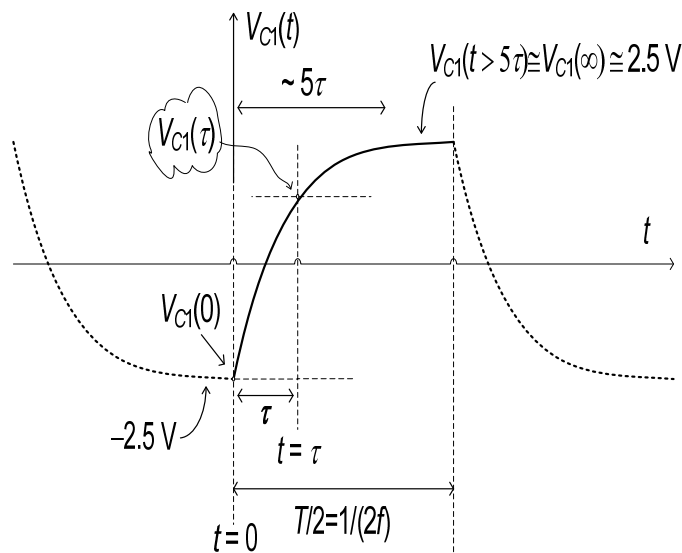

Figure 2. The capacitor voltage $V_{C1}(t)$ versus time t .

Next, in Fig. 1, change the source frequency to $f = 5 \text{ kHz}$ and then 50 kHz . (No need to measure the time constant again because it is the same.) For each frequency, observe $V_S(t)$ and $V_{C1}(t)$ voltage waveforms simultaneously with respect to time. Sketch and label these waveforms. Based on your observations, explain what happens and why this circuit is referred to as a Low-Pass Filter (LPF).

Next, switch the places of the 10 nF capacitor and $10 \text{ k}\Omega$ resistor as shown in Fig. 3 and use the oscilloscope to observe the voltage waveforms $V_S(t)$ and $V_{R1}(t)$ simultaneously for each one of the above source frequencies which are 500 Hz , 5 kHz , and 50 kHz . Sketch and label the waveforms. Explain why this circuit is referred to as a High-Pass Filter (HPF).

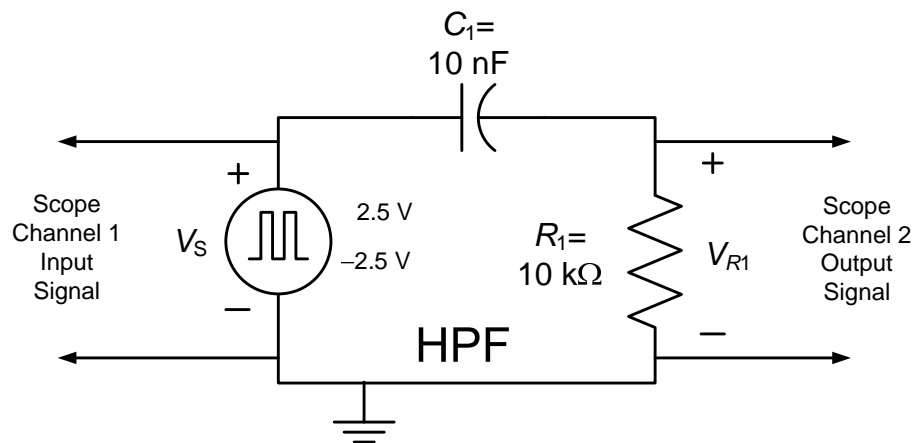

Figure 3. First-order RC circuit connected like a High-Pass Filter (HPF).

Pre-lab Assignment A.2: For the first-order RC circuit considered in Fig. 1, introduce a second resistor $R_2 = 2.2 \text{ k}\Omega$ in parallel with resistor $R_1 = 10 \text{ k}\Omega$ as shown in Fig. 4. Calculate the new value of the time constant $\tau_{\text{pre-lab}}$ or τ_p for this circuit and the approximate time it takes for the capacitor to fully charge or discharge.

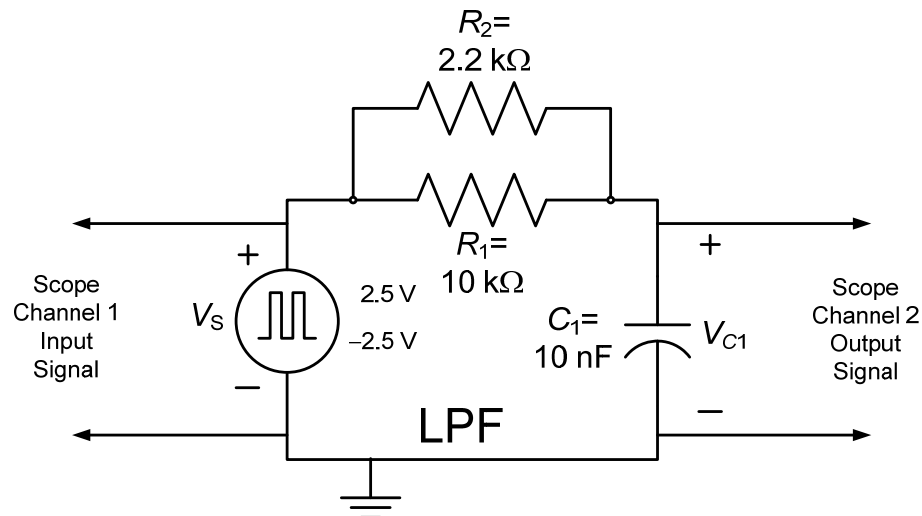

Figure 4. First-order RC circuit connected like a Low-Pass Filter (LPF).

Lab Experiment A.2: For the first-order RC circuit shown in Fig. 4, measure and record the actual value of the $2.2\text{ k}\Omega$ resistor using the digital LCR meter. Recalculate the actual time constant τ_a using the actual element values measured. Set the source frequency to 500 Hz . Set-up the oscilloscope connections so that both $V_S(t)$ and $V_{C1}(t)$ waveforms appear on the screen simultaneously. Sketch and label the waveforms.

- Measure the time constant τ_m using the $V_{C1}(\tau)$ voltage point on the $V_{C1}(t)$ waveform seen on the oscilloscope display.
- Calculate the percentage error in the τ_m value measured using

$$\% \text{ error in } \tau_m \text{ value} = \left| \frac{\tau_a - \tau_m}{\tau_a} \right| \times 100$$

Pre-lab Assignment A.3: For the first-order RC circuit considered in Fig. 1, introduce a second capacitor $C_2=100\text{ nF}$ in parallel with $C_1=10\text{ nF}$ as shown in Fig. 5. Calculate the new time constant $\tau_{\text{pre-lab}}$ or τ_p of the circuit and the approximate time it takes for the two capacitors to fully charge or discharge.

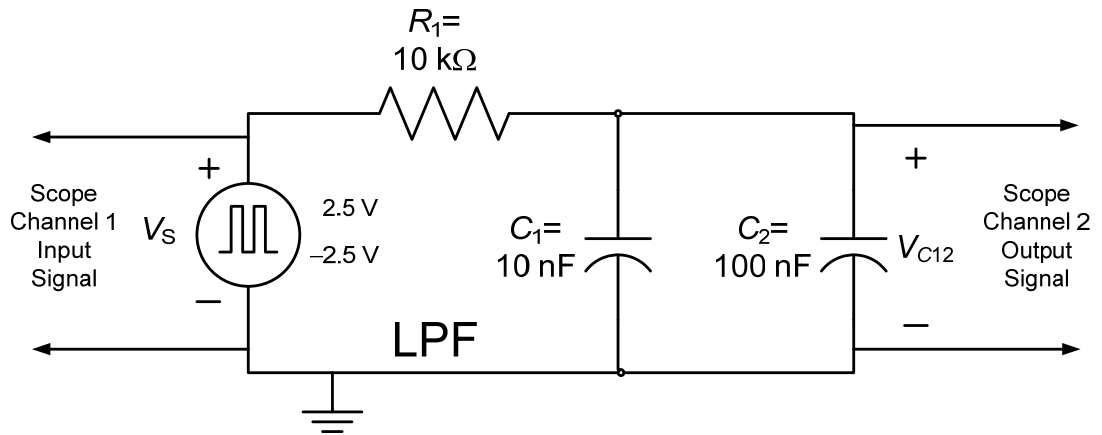

Figure 5. First-order RC circuit connected like a Low-Pass Filter (LPF).

Lab Experiment A.3: Construct the first-order RC circuit shown in Fig. 5. Measure and record the actual value of the 100 nF capacitor using the digital LCR meter. Recalculate the actual time constant τ_a using the actual element values measured. Set the source frequency to 50 Hz . Observe both $V_S(t)$ and $V_{C12}(t)$ waveforms on the oscilloscope display simultaneously. Sketch and label the waveforms.

- Measure the time constant τ_m using the $V_{C12}(\tau)$ voltage point on the $V_{C12}(t)$ waveform seen on the oscilloscope display.

- Calculate the percentage error in the τ_m value measured using

$$\% \text{ error in } \tau_m \text{ value} = \left| \frac{\tau_a - \tau_m}{\tau_a} \right| \times 100$$

III. Discussions & Conclusion

In this section, discuss the various aspects of Experiment #6 and make some conclusions. In your write-up, you should at least address the following questions:

1. What was the objective of this experiment and was the objective achieved?
2. Did any of your measurements have more than 5% error? What was your maximum % error?
3. What sources of error may have contributed to the differences between the theoretical values and the measured values?
4. Other comments relevant to this experiment.