

ME 401 – Machine Design  
Assignment 1 – Criteria and design

**SOLUTIONS**

Problem 1 – solved on separate page (separate pdf)

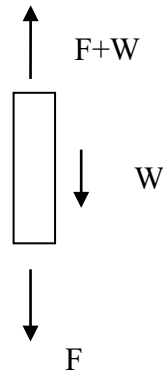

From Mohr's circle it is noted that the maximum shear stress for uniaxial loading is one-half the normal stress. Therefore, the allowable normal stress is twice the allowable shear stress =  $2 * 59,872 \text{psi} = 119,744 \text{psi}$

$$\sigma = F/A, \text{ therefore: } F_{\text{applied}} = \sigma * A$$

Assume:

Force is uniformly distributed (attachment stress is not to be considered)

For the level of precision requested, weight is **not negligible!** The weight is added to the total force, therefore the allowable force is:

$$F_{\text{allowable}} = F_{\text{applied}} - \text{Weight} = \sigma * A - \text{weight}$$

**Answer:** the applied force decreases as length increases. If weight is neglected, then 5877.930 pounds can be applied. For a 4" long bar, 5877.860 pounds can be applied.

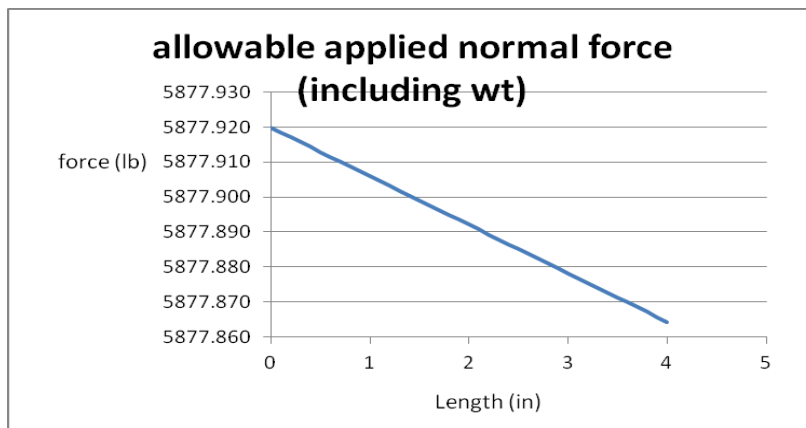

2. Your knowledge of unit prefixes is very important!  
*Answers: indeed, units are important, but easy to look up....*
3. Your knowledge of units is very important! If you don't know the units, then you do NOT understand the relevant concept sufficiently well!  
*Answers – like questions number 2 – these are all easy to look up. However, my quick internet search for “3d) Is stress a vector?” produced blogs with very interesting and creative answers, that were mostly very wrong. The correct answer is “NO”. Mathematically, scalars are zero<sup>th</sup> order tensors, vectors are first order tensors and stress (and strain) are second order tensors. Stress has magnitude, direction and “type” (normal and shear). Same with strain.*
4. There are a few basic material properties that every mechanical engineering student should have memorized by now. Here are two: what is Young's modulus of steel? What is Young's modulus of aluminum? Express your answers in both SI (GPa) and English units (Mpsi). *Answer:  $E_{steel} = 30 \text{ Mpsi} (210\text{GPa})$ ,  $E_{alum}$  is one-third that of steel (10Mpsi, 70GPa). Note that the elastic properties ( $E$ ,  $\nu$ ,  $G$ ) vary very little between alloys – all aluminum alloys have Young's modulus of about 10Mpsi, and all steels are about 30Mpsi.*
5. As a review of material properties, concisely define the following (1 brief sentence each). You may include sketches and equations to help with communication.
  - a) Yield strength (general description) – *the stress below which a material behaves elastically, above which it becomes permanently deformed.*
  - b) Yield strength based on 0.2% offset (what is meant by 0.2% offset?). *For materials which do not have a distinct yield point (most materials do not), an unambiguous method to define the yield strength is to draw a line of slope equal to Young's modulus starting at 0.2% strain (0.002in/in). Where that line crosses the stress-strain curve is considered to be the 0.2% offset yield strength.*
  - c) Dislocation – *a linear defect in a crystal. Movement of dislocations is expressed macroscopically as plastic deformation.*
  - d) Dislocation slip, dislocation glide, and dislocation motion are different ways of trying to describe the same phenomena. Concisely, describe the phenomena – what is “dislocation slip”? What type of stress causes dislocation slip (dislocation glide, dislocation motion)? Macroscopically, what does dislocation slip manifest itself as? *Answer: The movement (“slip” or “slide”) of a dislocation through a crystal is known as dislocation slip. Shear stress causes dislocation slip. Macroscopically, this is plastic deformation.*
  - e) Tensile strength (also referred to as ultimate tensile strength) – *the largest stress (highest point) a material carries in a tensile test.*
  - f) Compression strength (also referred to as ultimate compressive strength) – *the largest stress (highest point) a material carries in a compression test.*
  - g) Hardness – *resistance to local deformation. It is often relatively easy and inexpensive to measure.*
  - h) Show that Hooke's law for three dimensional stress becomes  $E = \sigma / \epsilon$  for uniaxial loading. *3D Hooke's law:  $\epsilon_x = [\sigma_x - \nu(\sigma_y + \sigma_z)] / E$  For uniaxial loading in the x-direction,  $\sigma_y = \sigma_z = 0$ , therefore  $\epsilon_x = \sigma_x / E$*

- i) Young's modulus – *the slope of the linear portion of a stress-strain curve, calculated by Hooke's law ( $E = \sigma/\epsilon$ ).*
- j) Poisson's ratio – *the ratio of the transverse strain to the axial strain in a uniaxial tensile test.*
- k) Toughness – *amount of energy required to fracture a material.*
- l) Ductility (in words and equations) – *the "amount" a material can stretch before fracturing (strain at fracture)  $\%EL = (l_f - l_o)/l_o \times 100\%$ . Also is expressed as reduction of area,  $\%RA = (A_o - A_f)/A_o \times 100\%$*
- m) Ductile fracture – *a fracture involving plastic deformation.*
- n) Brittle fracture – *a fracture not involving plastic deformation.*
- o) Describe (equations and words) the following failure criteria, and describe the general material classifications for which each is appropriate to use:  
 von Mises (aka Maximum distortion energy): *used for ductile materials; states failure (yielding) will occur when the distortion strain energy per unit volume in the part equals or exceeds the distortion strain energy per unit volume present in uniaxial loading. Yielding in the part will occur if:*

$$\{ [(\sigma_1 - \sigma_2)^2 + (\sigma_2 - \sigma_3)^2 + (\sigma_3 - \sigma_1)^2]^{1/2} / 2^{1/2} \} > \sigma_{ys}$$

maximum shear stress (aka Tresca): *used for ductile materials states failure (yielding) will occur when the maximum shear stress in the part equals or exceeds the shear stress present in uniaxial loading at the onset of yielding. Mohr's circle for uniaxial loading at the onset:*

*Yielding in the part will occur if:*

$$\tau_{max} = (\sigma_1 - \sigma_3) / 2 > \sigma_{ys} / 2$$

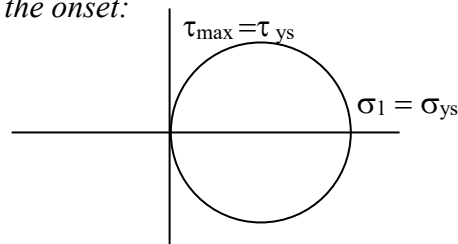

*maximum normal stress: used for brittle materials; states failure (fracture) will occur when  $\sigma_1 > \sigma_{UT}$*

- p) Explain why the maximum shear stress theory predicts the onset of yielding so well for ductile metals/alloys. In other words, what does the shear stress in a metal have to do with yielding?  
*Ans: shear stress causes dislocation slip, dislocation slip manifests itself macroscopically as yielding (plastic deformation). Therefore, determining the maximum shear stress in a part is useful in predicting plastic deformation (yielding).*
- q) Show the following relationships between the shear strength ( $\tau_{ys}$ ) and yield strength ( $\sigma_{ys}$ ). Maximum shear stress failure criterion  $\tau_{ys} = 0.5\sigma_{ys}$  and that for the von Mises criterion  $\tau_{ys} = 0.577\sigma_{ys}$ .

*ANS: From part (o) above, the maximum shear stress theory predicts the maximum allowable shear stress in the part (before yielding is  $\tau_{max} = 0.5\sigma_{ys}$*

For von Mises, consider the case of pure torsion (which is produced in circular shafts with torsional loads only). In such conditions,  $\tau_{max} = \sigma_1 = -\sigma_3$  and  $\sigma_2 = 0$ . For

Mohr's circle for pure shear:

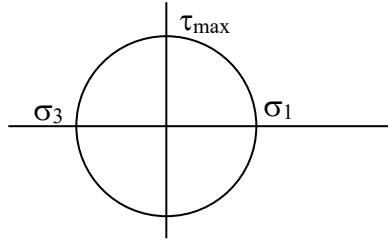

The von Mises criterion states yielding will occur if:

$$\{[(\sigma_1 - \sigma_2)^2 + (\sigma_2 - \sigma_3)^2 + (\sigma_3 - \sigma_1)^2]^{1/2} / 2^{1/2}\} > \sigma_{ys}$$

As above, for pure shear  $\tau_{max} = \sigma_1 = -\sigma_3$  and  $\sigma_2 = 0$ , the von Mises equation becomes:

$$\begin{aligned} \{[(\sigma_1 - \sigma_2)^2 + (\sigma_1 - \sigma_3)^2 + (\sigma_2 - \sigma_3)^2]^{1/2} / 2^{1/2}\} &= \\ \{[(\sigma_1 - 0)^2 + (\sigma_1 - (-\sigma_1))^2 + (0 - (-\sigma_1))^2]^{1/2} / 2^{1/2}\} &= \\ \{[6\sigma_1^2 / 2]^{1/2}\} &= (3\sigma_1^2)^{1/2}. \text{ According to von Mises, yielding will occur when} \\ (3)^{1/2} \sigma_1 &= \sigma_{ys}. \text{ From Mohr's circle, } \tau_{max} = \sigma_1 \text{ (pure shear). Combining these} \\ \text{gives: } (3)^{1/2} \tau_{max} &= \sigma_{ys} \text{ and solving gives } \tau_{max} = 0.577 \sigma_{ys} \end{aligned}$$

**NOTE A:** For the following 3 problems (6, 7, 8), in addition to the specific question asked, answer the following as well:

- If the part were made of a ductile alloy, what yield strength would be required for a factor safety of 2 against yielding?
- If the part were made of a brittle material, what tensile strength is required for a factor of safety of 2 for fracture?

Factor of safety in general is described as: FOS = “material strength”/”actual load”

6. Create Mohr's circle for the stress condition in a flat plate (3 inches wide, 0.250 inch thick, 10 inches long) with a 5000 pound load. State all assumptions. What are the maximum and minimum principal stresses and what is the maximum shear stress in the plate. What is the “von Mises stress” (aka “effective stress”)? Briefly describe how the stress varies within the plate. **Don't forget to answer NOTE A (above).**

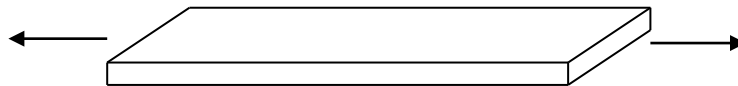

**Assumption:** uniformly distributed load throughout the plate (uniform stress).

Mohr's circle:

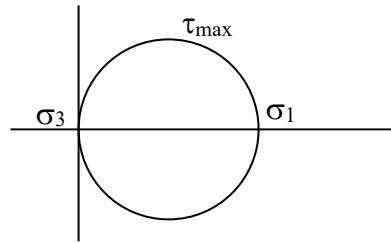

$$\sigma_1 = F/A = 5000\text{lb}/\{(3\text{in})(0.25\text{in})\} = 6600\text{lb}/\text{in}^2 = 6600\text{psi}$$

$$\sigma_3 = \sigma_2 = 0$$

$$\tau_{\max} = \frac{1}{2} \sigma_1 = 3300\text{psi}$$

$$\text{von Mises stress} = \sigma_{\text{eff}} = [\{(\sigma_1 - \sigma_2)^2 + (\sigma_2 - \sigma_3)^2 + (\sigma_3 - \sigma_1)^2\}/2]^{1/2}$$

$$= [\{(6600\text{psi} - 0)^2 + (0 - 0)^2 + (0 - 6600\text{psi})^2\}/2]^{1/2} = 6600\text{psi} = 6.6 \text{ ksi}$$

Note, if the bar is loaded along the x-axis, then  $\sigma_x = \sigma_1$  and  $\sigma_y = \sigma_z = \sigma_2 = \sigma_3 = 0$

- If the part were made of a ductile alloy, what yield strength would be required for a factor safety of 2 against yielding? *According to the maximum shear stress theory (aka Tresca theory of yielding) when  $\tau_{\max}$  equals or exceeds half the yield strength of the material, yielding will occur (plastic deformation). In this part, yield strength for FOS of 2 against yielding is  $2 * 6.6\text{ksi} = \underline{13.2\text{ksi}}$ . The distortion energy theory would also suggest a yield strength of  $\underline{13.2\text{ksi}}$ .*
- If the part were made of a brittle material, what tensile strength is required for a factor of safety of 2 for fracture? *According the maximum tensile stress theory, brittle materials will fail when the maximum normal stress ( $s_1$ ) equals the tensile strength the part will break. In this part, a tensile strength for a FOS of 2 against fracture is  $\underline{13.2\text{ksi}}$ .*

7. Create Mohr's circle for the stress condition in a round bar (2 inch diameter, 10 inches long) with a torsion load of 500 ft-lb. State all assumptions. What are the maximum and minimum principal stresses and what is the maximum shear stress in the bar? What is the "von Mises stress" (aka "effective stress") at the surface? Briefly describe how the stress varies within the bar. **Don't forget to answer NOTE A.**



**Assumption and answer to the last question:** from end-to-end uniformly distributed load throughout the bar (uniform stress), from center to outer surface stress goes from zero to maximum varying linearly. Also assume linear elastic material.

Mohr's circle:

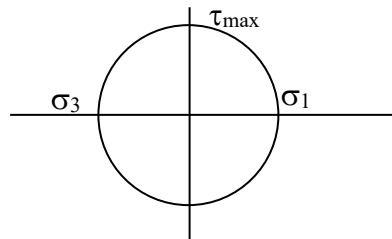

$$\tau_{\max} = Tr/J = \{[(500\text{ft}\cdot\text{lb})(12\text{in}/\text{ft})(1\text{in})] / \{\pi(2\text{in})^4/32\}\} = 3.82\text{ksi}$$

$$\sigma_1 = -\sigma_3 = \tau_{\max} = 3.8\text{ ksi}, \sigma_2 = 0$$

$$\begin{aligned} \text{von Mises stress} = \sigma_{\text{eff}} &= [\{(\sigma_1 - \sigma_2)^2 + (\sigma_2 - \sigma_3)^2 + (\sigma_3 - \sigma_1)^2\}/2]^{1/2} \\ &= [\{(3800\text{psi} - 0)^2 + (0 - (-3800\text{psi}))^2 + (-3800\text{psi} - 3800\text{psi})^2\}/2]^{1/2} = 6580\text{psi} = \\ &6.6\text{ ksi} \end{aligned}$$

- If the part were made of a ductile alloy, what yield strength would be required for a factor safety of 2 against yielding? Ans: According to Tresca theory:  $S_{ys} = \sigma_{ys} = 2\tau_{\max} \cdot \text{FOS} = 2(3.8\text{ksi}) \cdot 2 = \mathbf{15.2\text{ksi}}$  (von Mises:  $S_{ys} = \sigma_{ys} = \mathbf{13.2\text{ksi}}$ )
- If the part were made of a brittle material, what tensile strength is required for a factor of safety of 2 for fracture? According to max tensile strength theory, to prevent failure (fracture),  $S_{ut} = \text{FOS} \cdot \sigma_1 = 2 \cdot 3.8\text{ksi} = \mathbf{7.6\text{ksi}}$

8. For the simply supported beam shown below, precisely where (what point on the beam) is the bending stress maximum? Determine the maximum bending stress at that point. At that point, what are the maximum and minimum principal stresses, what is the maximum shear stress, and what is the “von Mises stress”? Briefly describe how the stress varies in the bar. Draw a complete free body diagram and create the shear and moment diagrams. The beam is 1000 mm long and a 2kN load is applied 200 mm from the left end. The beam’s height is 20mm and it is 10mm wide. State all assumptions. **Don’t forget to answer NOTE A.**

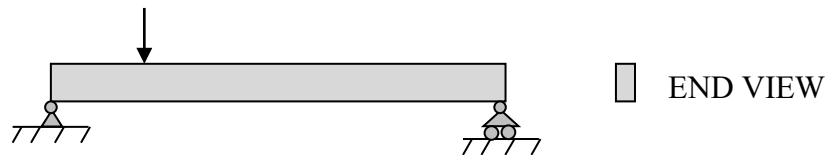

Assumptions: beam has negligible weight, linear elastic, small deformation

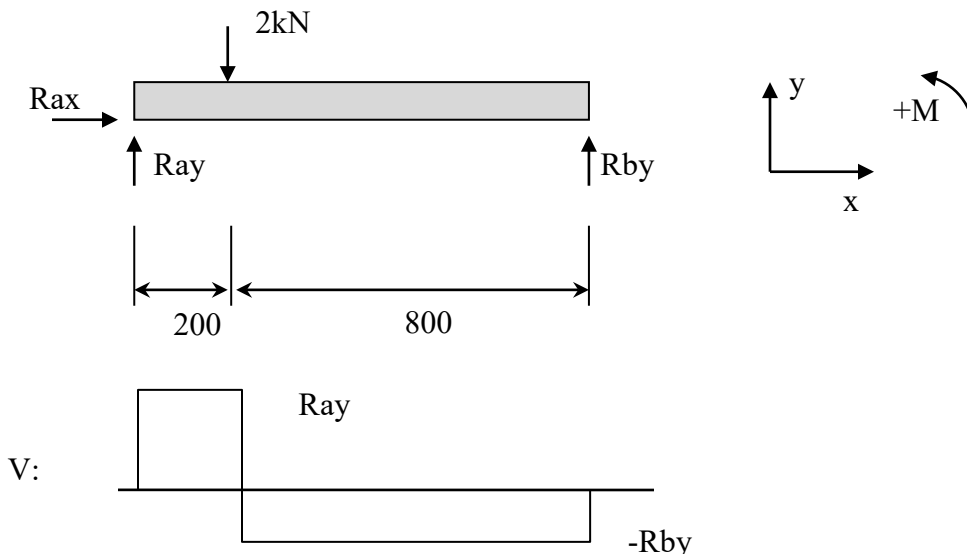

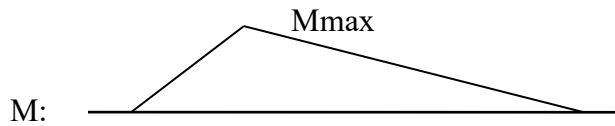

Bending stress varies linearly from zero at the supports to a maximum at the load application point. It varies linearly from maximum tension at the bottom to maximum compression at the top and is zero at the neutral axis. The maximum stress occurs at the location of maximum bending moment at a distance furthest from the neutral axis (top or bottom of the beam).

Determine reactions:

$$\Sigma M_a: -2\text{kN}(200\text{mm}) + R_{by}(1000\text{mm}) = 0; \quad \underline{R_{by} = 0.4\text{kN}}$$

$$\Sigma F_y: R_{ax} - 2\text{kN} + R_{by} = 0; \quad \underline{R_{ax} = 1.6\text{kN}}$$

Determine maximum moment:

$$M_{\text{max}} = R_{ay}(200\text{mm}) = \underline{320 \text{ kN-mm} = 320 \text{ Nm}}$$

Determine maximum bending stress:

$$\sigma = My/I;$$

$$M = 320 \text{ Nm (from above)} = 320,000\text{N-mm}$$

$$\text{At the top and bottom of the beam: } y = h/2 = 10\text{mm}$$

$$I = bh^3/12 = (10\text{mm})(20\text{mm})^3/12 = 6667\text{mm}^4$$

$$\sigma = (320,000\text{N-mm})(10\text{mm}) / (6667\text{mm}^4) = 480\text{N/mm}^2 = \underline{480\text{MPa}}$$

(Note: if the axis of the beam is along the x-direction and the y-direction points up (z is out of the page), then the bending stress is also  $\sigma_x$  and it is also  $\sigma_1$ . And  $\sigma_y = \sigma_z = 0$  and at the bottom and top of the beam,  $\tau_{xy} = 0$ ). Mohr's circle at the bottom of the beam (note, stress is NOT uniform in beams and the bending stress is NOT the principal stress at every point):

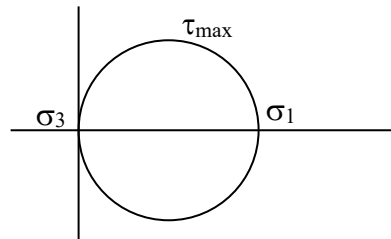

- If the part were made of a ductile alloy, what yield strength would be required for a factor safety of 2 against yielding? Ans: According to Tresca theory:  $S_{ys} = \sigma_{ys} = 2\tau_{\text{max}} * \text{FOS} = 2(480\text{MPa}/2)*2 = 960\text{MPa}$  (**von Mises:  $S_{ys} = \sigma_{ys} = 960\text{MPa}$** )

- If the part were made of a brittle material, what tensile strength is required for a factor of safety of 2 for fracture? According to max tensile strength theory, to prevent failure (fracture),  $S_{ut} = FOS \cdot \sigma_1 = 2 \cdot 480 \text{MPa} = 960 \text{MPa}$

9. Determine the reaction on the hub of the following system when the 10kg mass is located at a point as shown. The link is 10 cm long and the angular speed is constant at 500 rpm. State all assumptions and include a free body diagram of the mass.

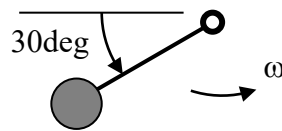

Assume: massless, rigid rod, gravity is acting downward (NOTE, this last assumption may be different – you were told that gravity could be neglected).

Solution:

FBD:

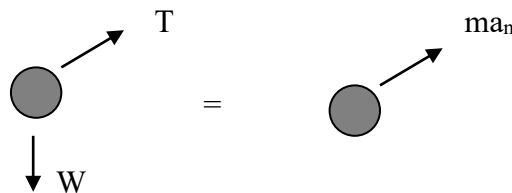

T is the force in the rod and it is the reaction force at the hub that we are seeking.

$$W = mg = 10\text{kg} (9.8\text{m/s}^2) = 98.1\text{N}$$

$$\omega = 500 \text{ rev/min} (2\pi \text{ rad/1rev})(1\text{min}/60\text{sec}) = 52.36 \text{ rad/sec}$$

$$a_n = v^2/r = r^2 \omega^2/r = r \omega^2 = (0.1\text{m})(52.36)^2 = 247.2 \text{ m/sec}^2$$

$$\text{Sum of forces along direction of rod: } \Sigma F_{\text{rod}} = ma_n$$

$$T - W \cos 60^\circ = m r \omega^2$$

$$T = W \cos 60^\circ + m r \omega^2 = 98.1\text{N} \cos 60^\circ + 10\text{kg}(0.1\text{m})(52.36/\text{sec})^2 = 2791\text{N} = \underline{2800\text{N}}$$

*But most of you probably neglected gravity, which was a viable option:*

$$\text{Without gravity: } T = m r \omega^2 = 10\text{kg}(0.1\text{m})(52.36/\text{sec})^2 = \underline{2740\text{N}} \text{ at } 30 \text{ degrees}$$

10. Observe the design of various things you use. In a future assignment you will be asked to describe something “well” designed and something “poorly” designed – so keep your eye out for such things. **No submitted work required**