

ME 328 – Machine Design  
Assignment 3, 2020

*Stress concentrations are very important in all real load carrying structures. All structures have stress concentrations (a.k.a. stress risers) and ultimately, fatigue failures almost always originate at stress concentrations! Therefore, it is very important for engineers understand what they are, and the effect they have on stress.*

**Educational Purpose:** *Help students learn to use stress concentration charts to determine **local stress** (stress at geometric discontinuities such as holes and fillets). The first problem helps students compare the “pro’s and con’s” of finite element analysis and stress concentration charts. One of the pro’s of FEA is the ability to “see” stress. Another advantage of FEA is that complex geometry and loading conditions can be analyzed. However, Problem 2 helps show that the stress concentration charts can be a more effective design tool.*

*Before beginning this assignment, it is essential for you to understand the difference between the following two terms as they are applied to stress concentrations: “local stress” and “nominal stress” (“nominal” not “normal”). In your own words, describe or define (you do not need to turn this in):*

- a) *Local stress:*
- b) *Nominal stress:*

1. (12 pts total, 2 per part) Consider the two simple geometries shown below. In each analysis, assume the load is uniformly distributed at the ends and that the stress on the right edge is unit stress (1 psi). Assume the plates are 0.500 inch structural steel with  $E=30 \times 10^6$  psi,  $\nu = 0.27$  and  $S_{ys} = 100$  kpsi. For both of these, consider stress at three points: point A (the point of maximum stress), point B (as shown) and point C (far from the stress concentration). Answer these questions using the stress concentration charts discussed in class.
  - a) Using stress concentration charts, determine the maximum stress caused by stress concentration ( $\sigma_x$  at point A).
  - b) Draw a 2-dimensional stress element (plane stress) for points A, B and C in each geometry. By reasoning or calculation, determine  $\sigma_x$ ,  $\sigma_y$ ,  $\tau_{xy}$ , for these elements. Draw the corresponding Mohr’s circle for each of these.
  - c) Compare the answers for  $\sigma_x$  at points A, B, and C in question (b) above with the FEA printout (posted on the course web page).
  - d) For each bar, what would the stress on the right side of the bar have to be increased to such that it would cause local yielding (“local” = “at the stress concentration”)?
  - e) For each bar, what would the stress on the right side of the bar have to be increased to such that it would cause “bulk” yielding (“bulk” meaning the bar itself becomes elongated)? Think – where in each plate will this occur, then analyze the stress in that area.
  - f) For each bar, if the material was brittle with  $S_{UT} = 100$  kpsi, what would the stress on the right side of the bar have to be increased to such that it would cause it to fracture? Sketch where would it fracture.

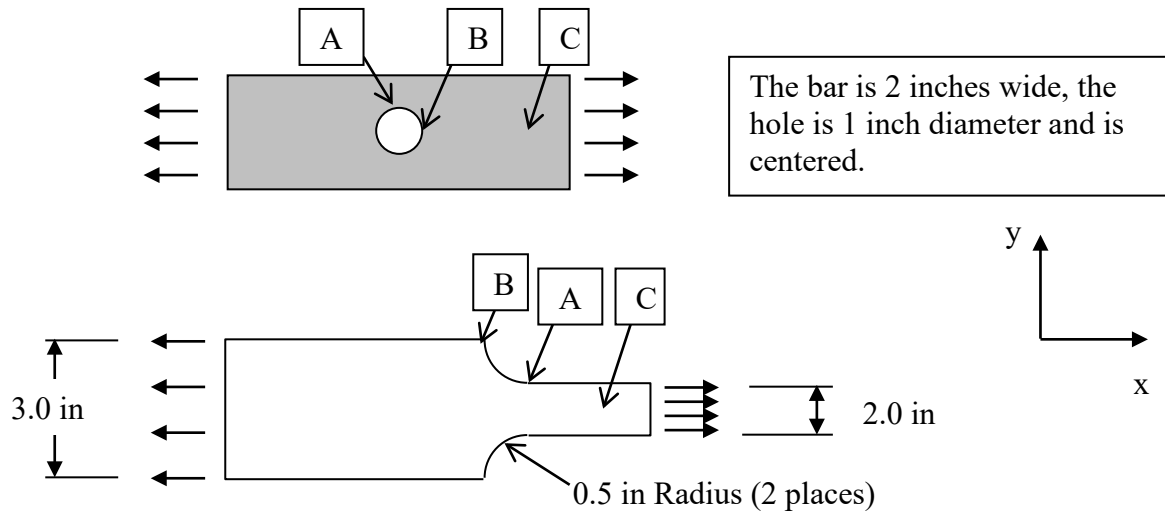

**DESIGN PROBLEM. Educational Purpose:** *The second problem shows that stress concentration charts can be used for parametric design analysis (the parameter being the hole diameter). FEA is not always a good design tool – it is a good analysis tool. The charts can effectively be used for design. Please see course web page for general requirements associated with homework using Excel. Why Excel? Many employers have commented that they want engineers who are competent with Excel.*

2. A flat bar (60mm wide and 5 mm thick) has an axial load of 1 N distributed at the ends. There is a hole in the middle of the plate as shown. Use Excel as follows:
  - a) 5 pts Determine an equation for the stress concentration factor ( $K_t$ ) as a function of  $d/w$ . To do this, plot at least 6 points from the appropriate  $K_t$  chart and then fit a trendline to the data. Have Excel show you the equation for the trendline.
  - b) 2 pts Use the equation generated in part (a) to determine the maximum stress near the hole as a function of hole diameter (ranging from 1mm to 20mm diameter).
  - c) 2 pts For a 10 mm diameter hole in the plate, what force is required to cause failure of a brittle ceramic material with  $S_{UT} = 150\text{MPa}$ ?
  - d) 2 pts For a 10 mm diameter hole in the plate, what force is required to cause failure (defined as local yielding = yielding at the stress concentration) for 2024-T3? (cite your source for obtaining material properties).
  - e) 2 pts For a 10 mm diameter hole in the plate, what force is required to cause bulk failure (defined by permanent elongation of the plate) for 2024-T3?

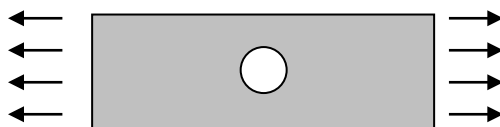

3. 5 pts *Purpose: use FEA to validate a common assumption.* A common assumption for uniaxial loaded structures is that the force is uniformly distributed; therefore,  $\sigma = F/A$  is valid. Using 2D plate elements, model a bar that is 1 inch wide (and 1 inch thick) and 10 inches long, with a force of 1 pound applied at a single point (as implied in the sketch below). You may use symmetry. Approximately, what is the distance from the end of the bar such that the axial stress is uniform through the cross-section? Assume “uniform” means the stress does not vary by more than about 5% within the cross-section.



ANSYS HINT: This should be an easy Script to modify from last semester. If you seem unable to find a relevant script, there probably are some on the ME304 web page. Once the model is created and successfully runs, then you may want to adjust the color-bar to help answer the question being asked. To do so: Right click over the color bar>Contour Properties>range. Enter a range of stresses such that there is a single color spanning 0.95psi to 1.00psi and a single color for 1.00psi to 1.05psi (those are the +/- 5% range we are looking for). You may need to play with this a bit to figure out precisely what you need to do.

4. 5 pts **Educational purpose:** *mechanical engineering has its own jargon and tools. It is important for engineers/students to be conversant in this jargon.* Define or describe the following terms, use sketches if appropriate, and cite your sources (URL's are acceptable if cited – even Wikipedia): what is the differences between a “pipe” and a “tube”, briefly describe sand casting and list 3 advantages and 3 disadvantages.
5. 0 pts **Educational purpose:** *it makes no sense to design something that cannot be built. So let's spend some time learning how somethings are built/made/used...* The following short videos provide more details about the few items we looked at in class. Watch the videos – nothing to submit with this assignment. Some of these should be postponed until we've had ICA on them
- Acumed, 4 minute animation about orthopedic screws (can skip the first 2:45)  
<https://www.youtube.com/watch?v=VXUW5riWR6M>
  - Chains, 9 minute video on home sand casting aluminum chains. Sand casting is a common industrial process.  
<https://www.youtube.com/watch?v=XT24Ya4UMyo>
  - Injection molding, 3 minute video demonstrating the concept of injection molding – a widely used process for making plastic parts:  
<https://www.youtube.com/watch?v=b1U9W4iINDiQ>
  - Wire EDM (Electrical Discharge Machining) 2:25 min  
<https://www.youtube.com/watch?v=pBueWfzb7P0>