

FIGURE 7.12

Design for manufacture of machined parts. (*Product Design: Techniques in Reverse Engineering and New Product Development*, by Otto/Wood, © 2001, Prentice-Hall. Reprinted by permission of Pearson Education, Inc., Upper Saddle River, NJ.)

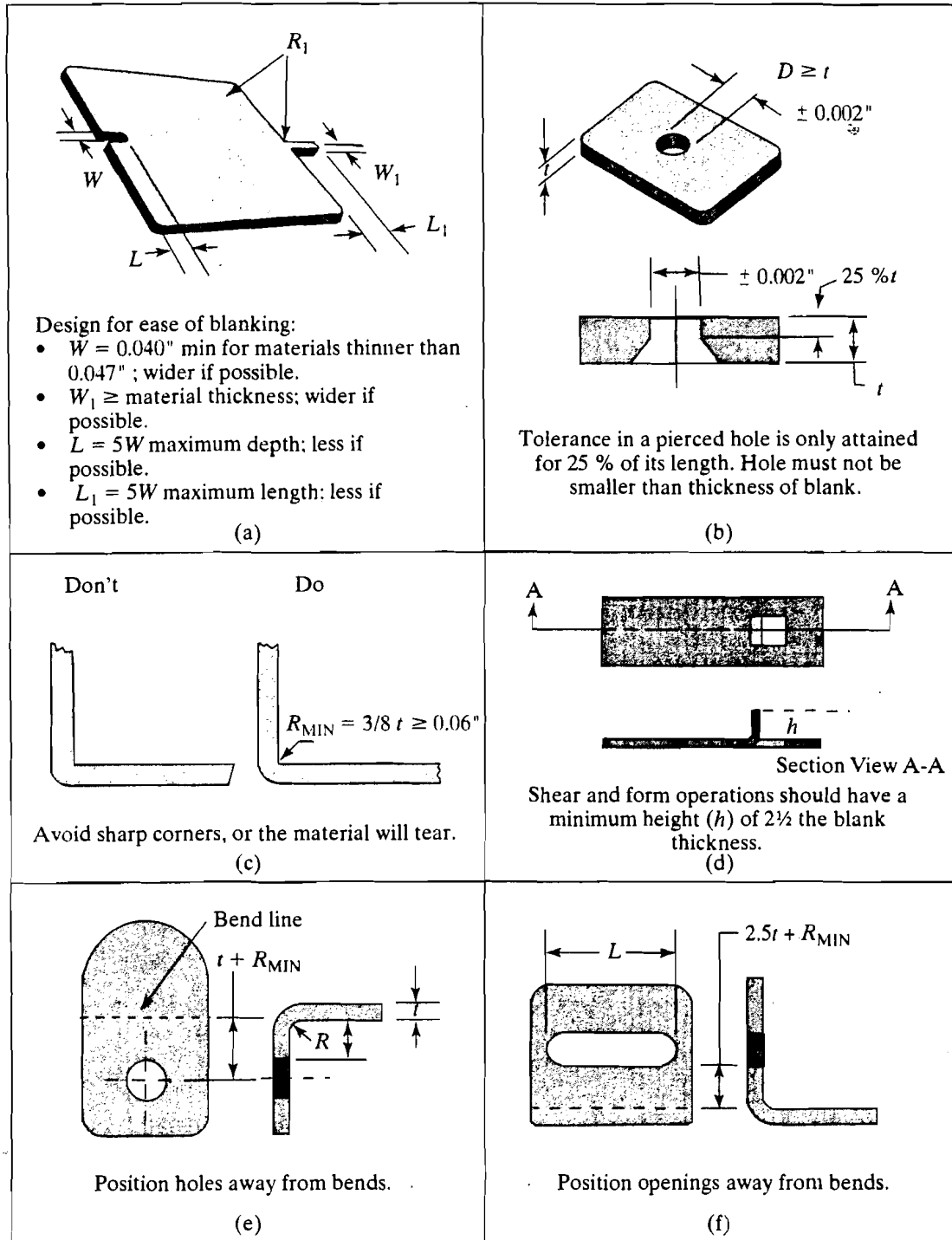

FIGURE 7.9

Design for manufacture of sheet metal parts. (*Product Design: Techniques in Reverse Engineering and New Product Development*, by Otto/Wood, © 2001, Prentice-Hall. Reprinted by permission of Pearson Education, Inc., Upper Saddle River, NJ.)

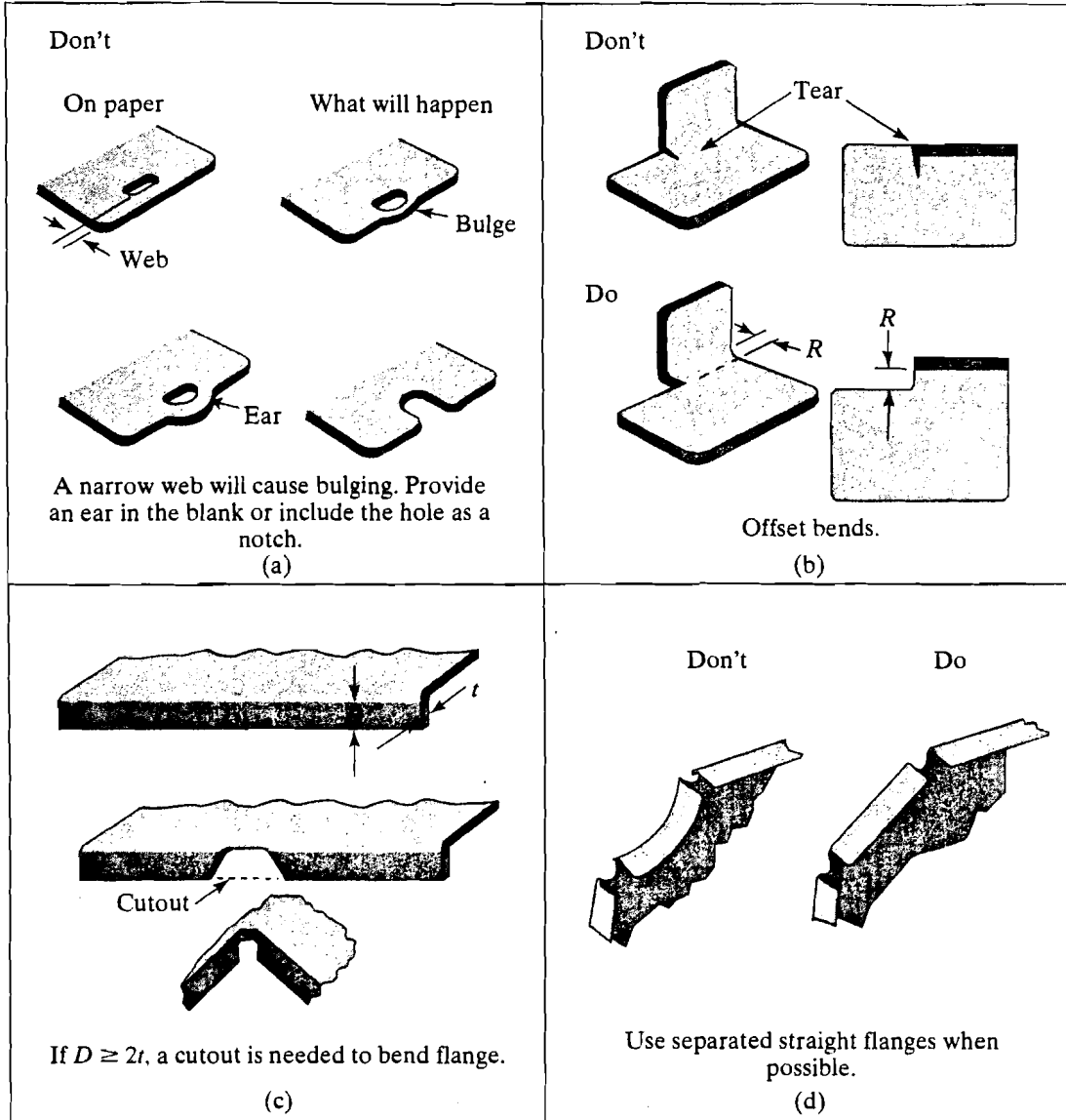

FIGURE 7.10

Design for manufacture of sheet metal parts continued. (*Product Design: Techniques in Reverse Engineering and New Product Development*, by Otto/Wood, © 2001, Prentice-Hall. Reprinted by permission of Pearson Education, Inc., Upper Saddle River, NJ.)