

**The University of Portland**  
**Donald P. Shiley School of Engineering**  
**EE352**  
**Electronic Circuits**  
**Homework 7**

**Assigned:** Fri, Mar 27, 2020  
**Due:** Fri, Apr 3, 2020  
**Exam 2:** Mon, Apr 6, 2020 (Closed-Book, 2 crib-sheets, calculator)

**Problems:**

- 1) Consider the BJT Opamp circuit in Figure 1. Assume  $\beta_N=200$ ,  $V_{AF-N}=130$ ,  $\beta_P=50$  and  $V_{AF-P}=50$ .
  - a) Calculate  $A(s)=V_{out}/V_{in}(s)=A_0/(1+s/\omega_H) \approx \omega_t/s$  using hand-analysis. Calculate  $A_0$ ,  $\omega_H$  and  $\omega_t$ .
  - b) Plot the  $A(s)=A_0/(1+s/\omega_H)$  Bode Plots using Matlab.

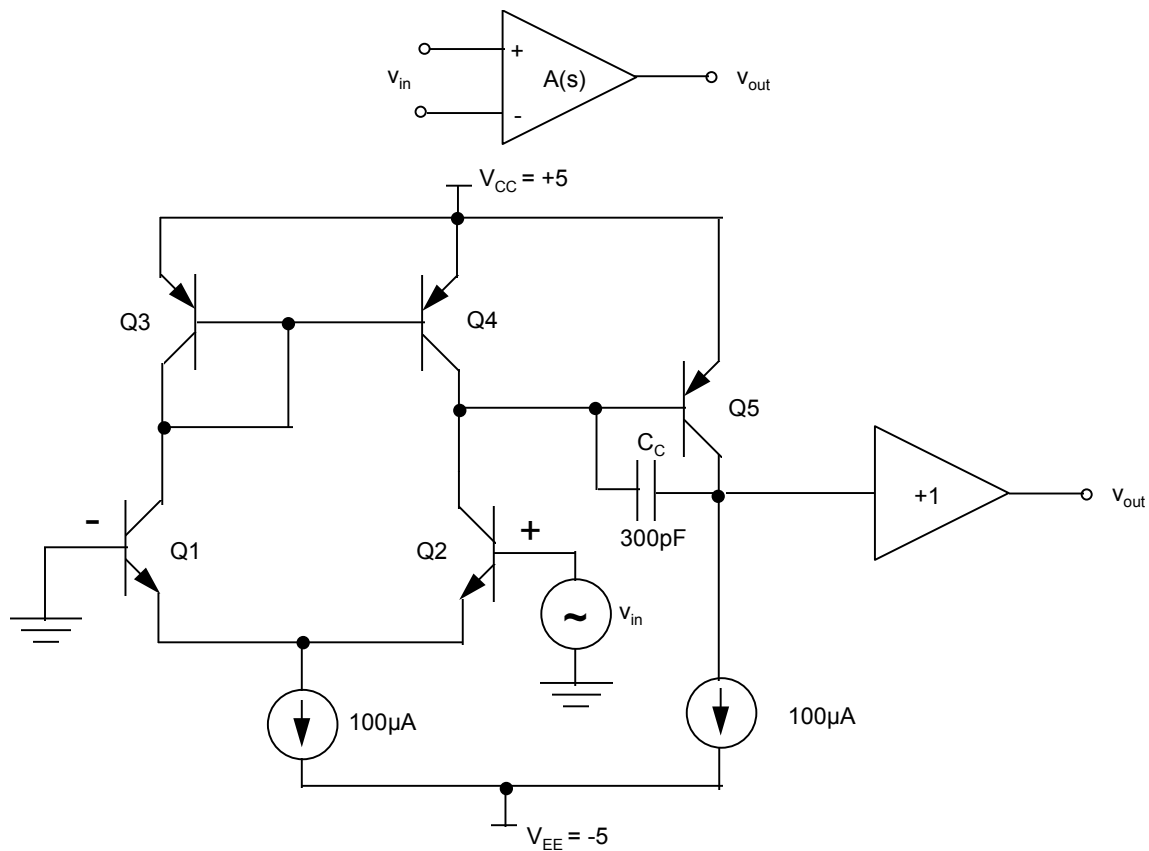

Figure 1.

- 2) Repeat Problem 1b, using PSPICE. Use an E-BOX (with a 1k ohm dummy resistor) for the unity gain output buffer, as explained in class. Use the following analyses: Transfer Function and AC Sweep (Type=Decade, Pts/Decade=10, Start=1, Stop=100MEG) with Bias Point Details turned on. Use QbreakN3 and QbreakP3. Use the following NPN and PNP models: NPN(BF=200 VAF=130 TF=500E-12) and PNP(BF=50 VAF=50 TF=30E-9). Use VAC input source at 1V. Please turn in all your properly annotated PSPICE printouts including your schematic, xxx.out file and your Probe Bode Plots. (Remember to show  $A_o$ ,  $R_{in}$ , and  $R_{out}$  in your .out file).
- 3) Now consider the opamp circuit in Figure 1 after it has been configured in its simple unity gain feedback configuration. Assume  $A(s) \approx \omega_t/s$ .
  - a) Calculate the closed-loop  $A_f(s) = V_{out}/V_{in}(s)$  using hand-analysis.
  - b) Calculate the  $\tau$  of the output for the SS step-response using hand analysis.
  - c) Calculate the slew rate, SR, of the output for the LS step-response using hand analysis.
- 4) Simulate the unity gain opamp circuit in Problem 3 using Transient Analysis in PSPICE to determine the SR. Use a VPULSE source with a  $\pm 500\text{mV}$  amplitude and the following settings: TD=TR=TF=0, PW=2.5 $\mu\text{S}$  and PER=5 $\mu\text{S}$ . Determine the SR from the output Probe Plot. (It should agree with your hand calculation above in Problem 3c). Please turn in all your properly annotated PSPICE printouts including your schematic and your output Probe Transient Analysis Plot.